



BAURAL

Straddle tractor tool carrier

**HIGH-TECH MACHINES FOR AGRONOMIC
RESEARCH AND SEED PRODUCTION**



Straddle tractors



Baural straddle tractor

A straddle tractor to meet your needs

Hydraulic steering
Minimized turning radius: 4.30 m outside
Front tyres: 6.00 R 16 (« 3 bands » steering drive)
Rear tyres: 7.50 R 20 (« V-shaped » driving system)
Authorize to drive on french roads

Frame

Mechanically welded tube structure
4 telescopic beams with adjustable height until 800 mm
Foldable protection top bar
4 fixing points at the back for equipment interchangeability
« Push-pull » coupling for a fast connection with the hydraulic system

Powerfull engine

DOOSAN Stage V engine (55ch, 41kw)
Liquid cooling system
Electrical start 12 Volts
Fuel tank of 65 liters or 100 liters in option

Transmission

Hydrostatic transmission (from 0 to 20 km/h)
Pump with variable volumetric size
POCLAIN wheel engine double volumetric size – two speeds with electric command
Hydraulic tank with cooler
Driving wheel engaged (optional)
Speed indicator (optional)





Spraying equipment

Tank and pump

Kuhn-Blanchard system
 Tank capacity of 400 liters
 Made of polyethylene shock-proof
 Hydraulic blending system
 Clear water tank
 Spraying pump hydraulically operated with electric command
 « Piston-membrane » pump 20L/min
 Pressure regulator from 0 to 30 bars



Control and command board

Pressure regulation
 Flow regulation
 Various controls (number of hours...)



Standard foldable handrail – treatment of 12 m

Foldable handrail in 5 parts with safety
 Width: 2.45 m
 Non-drip nozzles support
 Low position height of 0.50 m
 High position height of 2.50 m



Special handrail – located treatment

9 nozzles to treat 8 corn rows
 Foldable height in work position
 Horizontal inclination to move easily on field





Rapeseed separator

Separation system for rapeseed branches to make easier the harvest

- 4 cones with adjustable spacing distance
- Adjustable rotating speed
- 12 adjustable bars
- 2 Adjustable legs to follow the ground
- Foldable top protection bar
- Driver's seat at the back overhanging the field and the separating system



Separating cones lifted to easily maneuver at the end of the field



View on cones from driver's seat



Features

Engine

DOOSAN Stage V engine
55ch (41kw)

Liquid for cooling down
Electrical start 12 Volts
Fuel tank 65 liters or 100 liters (option)

Hydrostatic transmission

Pump with variable volumetric size
2 POCLAIN wheel engine with two volumetric size (2 speeds with electric command)
Speed from 0 to 20 km/h
Hydraulic tank with cooler
Interlocking of drive wheels (option)
Speed indicator (option)

Hydrostatic steering

Orbitrol with valve et steering cylinder

Tyres

AR 7.50 R 20
AV 6.00 x 16

Spraying equipment

Frame lifting : hydraulic lifting with electric command/stroke of 0,80 m
Hydraulic spraying handrail lifting with electric command/stroke of 1,40 m
Standard spraying handrail : 12 meters
Located spraying handrail : 9 nozzles with electric inclination
Tank of 400 liters, Kuhn – Blanchard pump
Control board

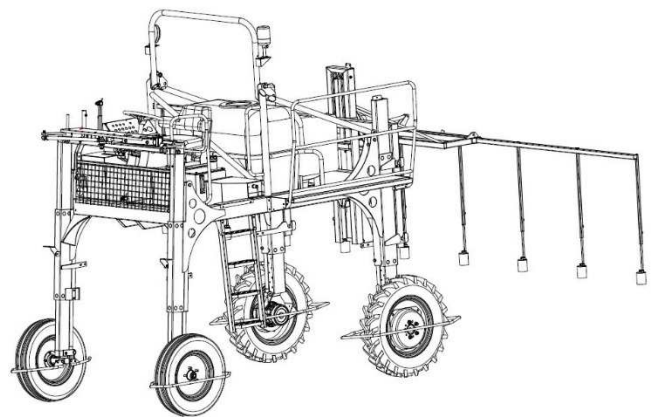
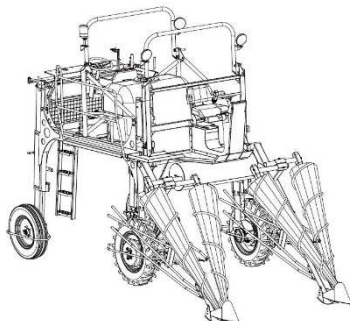

Rapeseed separators

4 separating cones with adjustable speed
Inverted driver's seat
Adjustable separation width

Dimensions and weight

Width without equipment : 2,15 m
Width with equipment : 2,45 m
Length without equipment : 3,40 m
Height without protection top bar : 2,60 m
Height with protection top bar : 3,10 m
Height from ground : 1,25 m (low position) and 2,05 m (high position)
Wheelbase : 2,50 m
Weight without equipment :
* Total : 1 500 kg
* Front axle : 580 kg
* Rear axle : 920 kg
Track : 1,80 m (or 1,60 m : to define)

Electric equipment

Control board
Batterie and alternator (12 V)
Traffic lights (option)

Others

Operating manual and spare parts catalogue
Ratification to drive on roads in France



Contact us

BAURAL

26 Rue du haut buisson

41330

Champigny-En-Beauce

France

+33 (0)2 54 33 11 01

Baural.contact@baural.fr

www.baural.fr

